

Training Pack

Safety Standard for Dismantling & Rearranging (D&R) of Cables and Conduits



➤ **Dismantling, Removing, or Rearranging (D&R) of**

Electrical conduits,

Cables and

Conductors,

excluding Bus Bars & Overhead Conductor.

Responsibilities - All Electrical Maintenance heads / Unit leaders / Electrical In-charge

Engineering Div. are responsible for job, in whose command area the job of Dismantling and Rearranging is being executed.

General Requirement for D&R job,

- Before employees are permitted to start any electrical D&R activity, a [competent person](#) must conduct a [survey](#) to determine the exact [scope of work](#) and the method for safely executing it.
- Depending upon the complexity of the work or the [hazards involved](#), [written job plan](#) may be required.
- The steps of the job plan procedure are not intended to address all situations. In case of the unique nature, the [competent person](#) shall exercise good judgment in determining appropriate execution methods.
- The D&R task shall be led by a [qualified person](#). Any person cutting or disconnecting conductors shall be a skilled Person.

Associated Hazards with D&R Jobs:-



- ⊕ Back feeds in the electrical equipment.
- ⊕ Induced / Residual voltage in cables.
- ⊕ Cutting the wrong cables.
- ⊕ Cutting through raceways containing energized cond.
- ⊕ Contacting energized conductors or parts.
- ⊕ Failure of another LIVE Cable during the job.
- ⊕ Inadvertent energisation of cable.
- ⊕ Operation of relays causing unwanted tripping due to vibration.
- ⊕ Incorrect labeling.
- ⊕ Hazardous environment such as Gas, Steam, Water etc.
- ⊕ Etc



Safety Guidelines

1- D&R of Cables or Conductors in Conduit

Safety Guidelines

1- D&R of Cables or Conductors in Conduit

- Cable or conductors to be D & R'd shall be electrically isolated as per existing Power Isolation procedure.
- If several cables or conductors are being D & R', they shall be cut one at a time.
- The job plan must clearly identify the boundaries of the work. It must be clear what doors or covers are to be opened and what doors and covers are not to be opened. These doors and covers must be physically identified like marking with identification tapes or signs.



Safety Guidelines

1- D&R of Cables or Conductors in Conduit

➤ Each cable to be D & R'd should be identified with a particular tape, such as 'Green', ensuring that the similar tape is not used in any adjacent cable for some other purpose.



➤ If D&R of cable or conductors from conduit involves removing some conductors in a conduit while some conductors are intended to remain as it is, then all the conductors must be De-energized, and Tagged. Excessive force must not be applied that can cause inadvertent damage to the remaining conductors or cables.



Safety Guidelines

1- D&R of Cables or Conductors in Conduit

- Conductors shall be tested for the absence of voltage, verified at all access points (pull boxes, junction boxes etc), with single function test device (3 bulbs test lamps for voltage up to 650 volt and suitable ht power tester for voltage above 650 volts).
- Proper operation of any test device must be verified , both before and after the test.
- Non contact test devices have limitations, such as not detecting dc voltage or not detecting ac voltage through metal sheath. The user should be knowledgeable of those limitations.
- After absence of the voltage has been verified, starting from the voltage supply end, the conductors shall be removed to the access point and cut.
- No conductor shall be cut until it has been physically removed to an access point.

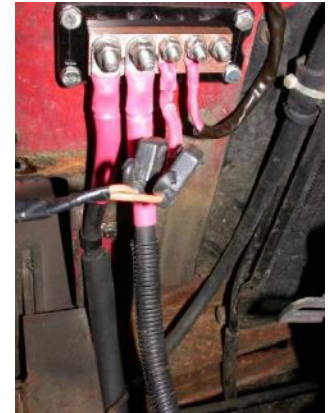

Safety Guidelines

2 - D&R of Cables in Trays



Safety Guidelines

2 - D&R of Cables in Trays

- It is recommended that out of service wiring/cables should be removed.
- If out of service wiring/cable is not physically removed, the minimum safe practice includes disconnecting and identifying, in a highly visible manner, cable(s) on both ends and indicating the location of opposite end. Out of service conductor ends shall be individually insulated.
- The D&R task shall be analyzed to determine if induced voltage could present a hazard. An example of this would be a long run cable in the same tray with energized cables. In those cases where hazardous induced voltage may exist competent person must analyze the job for an appropriate path forward. That analysis may indicate a ground must be installed on the opposite end of the cable from the direction the D&R will be done.

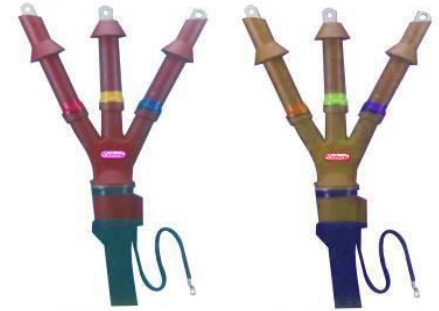

Safety Guidelines

2 - D&R of Cables in Trays

- Only reasonable force shall be applied while performing D&R of cables intertwined with other cables that are intended to stay in service. Excessive force could cause inadvertent damage to other cables.
- Tools used to cut cables shall not be positioned in a way that they may cause inadvertent damage to another cable.
- Cutting tools with insulated handle only should be used for this purpose.
- After all the cables intended to be D&R'd are removed from the tray the remaining cables shall be re-secured.



Following is the step by step procedure for D&R of cable in the tray.

- a. The cable shall be electrically isolated from both the **ends**.

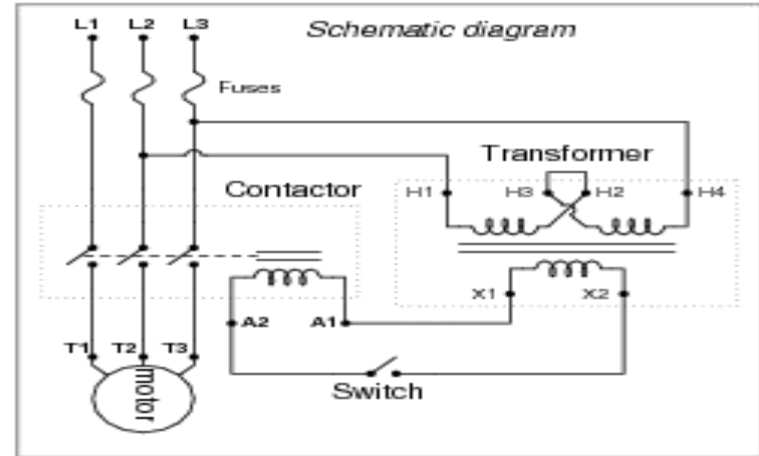
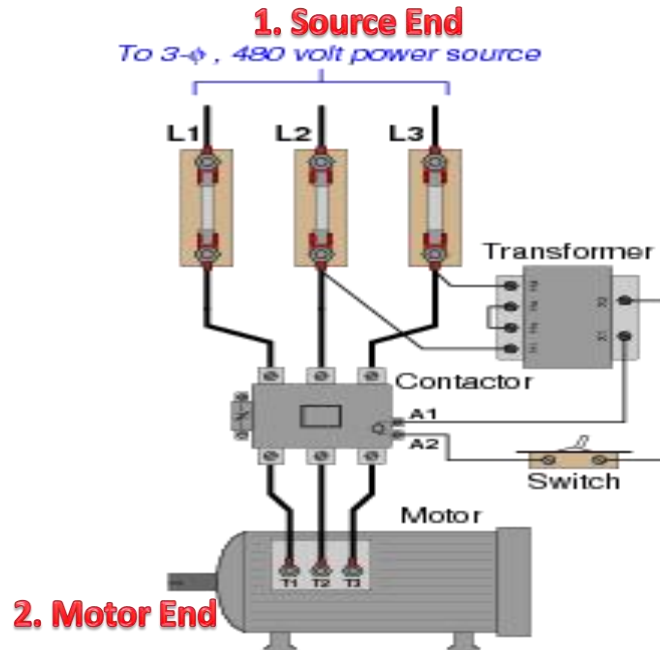

Following is the step by step procedure for D&R of cable in the tray.

- b. The cable shall be verified by continuity test.
- c. **Cable removal shall be started from the VOLTAGE SOURCE END.**
- d. If any cable in the tray is energized or has the potential to be energized then before the initiation of cutting of the cable the visual verification must be done from the end of the cable to the point of cut. This visual verification must be continuous along the length of cable. No cable shall be cut inside the boundaries of the cable tray. The cable shall be laid over the side or elevated above the wall of the tray.



Note:

If the cable is intertwined with other cables or passes through walls or partitions and it is impossible to have continuous length visual verification then the cable must be physically removed from the tray to achieve continuous length visual verification prior to cutting.

Pulling the cable back and forth in the tray by two persons is not an acceptable substitute for continuous visual verification and should never be depended upon for cable identification.

Safety Guidelines

3 - D&R of Conduits

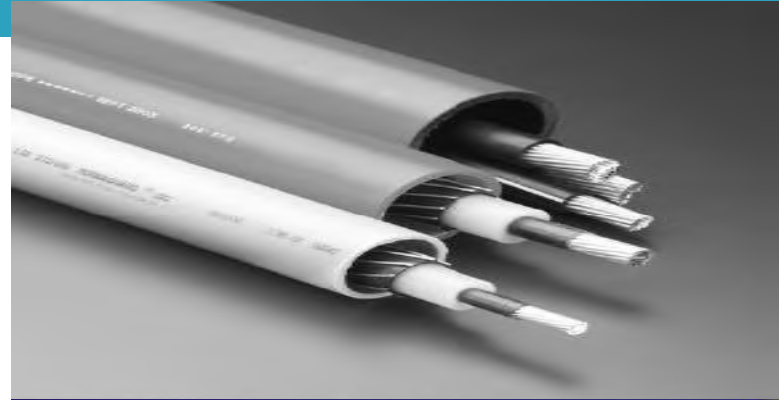

Safety Guidelines

3 - D&R of Conduits

- All junction boxes and pull box covers shall be removed prior to conduit D&R.

- If at all practical, the enclosed conductors should be removed prior to D&R of the conduit. If it is not practical to remove the conductors prior to conduit D&R, the conductors shall be disconnected at both end and absence of the voltage must be verified.

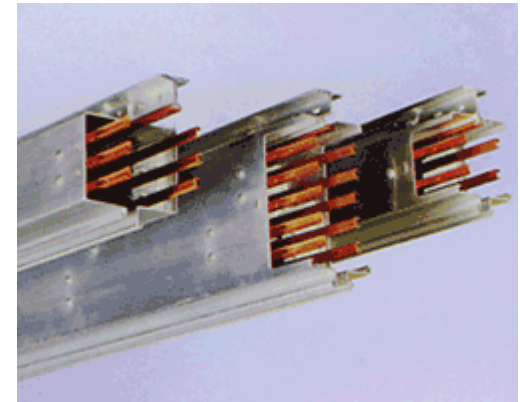

Safety Guidelines

3 - D&R of Conduits

- All effort should be made to **unscrew** the conduit rather than cutting it. If unscrewing is not practical, then Before the conduit is initially cut visual verification must exist from the end of the conduit to the point of cut. This **visual verification** must be continuous along the length of the conduit and must ensure that branches do not introduce another voltage source.
- All remaining holes after D&R of the conduit shall be plugged.



GUIDANCE ON DESIGN, APPLICATION AND CONSTRUCTION OF EARTHING SYSTEMS



Purpose

This Module Covers :

- Design,
- Application and
- Construction aspects of Earthing Systems

Earthing system for computers, electronic equipments, and communication system/equipments are **BEYOND THE SCOPE** of this standard.

General

The objectives of Earthing System are :

- To provide a **surface** under and around an electrical installation which shall be at a **uniform potential** and at as **nearly zero**, or **absolute earth potential** as possible.
- To ensure that in general all **parts** of apparatus other than live parts, shall be at **earth potential**.
- To minimize the risk of **step potential**.

Classification of Earthing system

❑ System/Neutral Earthing :

Electrical connection of neutral conductor of a 3-phase 4-wire system, middle conductor of a 2-phase 3-wire system, one point of single phase supply

OR

Artificial neutral point created by having earthing transformer in 3 phase, 3 wire system to general mass of earth.

Ensures that the voltage on each live conductor is restricted to such a value with respect to potential of general mass of earth, as is consistent with level of insulation applied and other safety requirements.



Classification of Earthing system

❑ **Equipment Earthing :**

Electrical connection of the non-current carrying metallic parts in the neighborhood of electrical circuits of apparatus/equipments to general mass of earth.

Ensures effective operation of protective gear in the event of leakage through such metal work, the potential of which with respect to neighboring objects may attain a value which would cause danger to life or risk of fire.

Design and Application

Important factors for the basis of design :

- I. Conductor of the earthing system or the metal part of equipment which is to be grounded.
- II. Point where the conductor is to be earthed.
- III. Size of the earth wire/lead and the arrangement of its mechanical protection and the mode of its connection to the earth electrodes.
- IV. Earth electrodes and the limitation of their resistance to the ground.
- V. Fault current of the system

Location of the earthing system with precise location of the earthing station shall be **shown in the Project Drawing** and **displayed** permanently and prominently **in the substation** for convenience of maintenance and testing personnel.

System/Neutral earthing system and Equipment earthing system shall be distinct and shall not be interconnected for system voltage of 11 kV and above.

For system voltage below 11 kV they may be interconnected as shown.

Drg.No.SD-1219

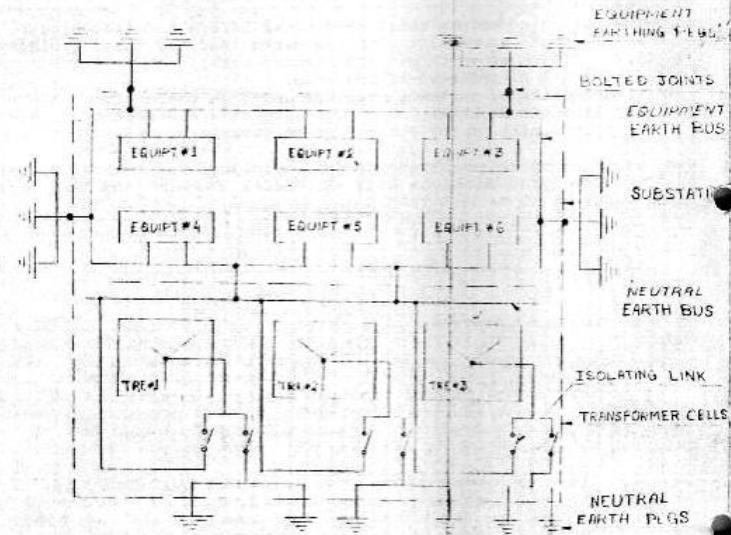

- NOTE - (1) NEUTRAL SYSTEM EARTHING ELECTRODES ARE INTERCONNECTED THROUGH A BUS LOCATED IN THE CELL INSTEAD OF CONNECTING EACH TO GROUND.
- (2) NEUTRAL BUS IS CONNECTED TO EQUIP EARTHING KING BUS AT THE PLACES WHERE JOINTS ACCESSIBLE EASILY (ONLY APPLICABLE FOR SYSTEM VOLTAGE BELOW 11kV).
- (3) EQUIPMENT EARTH BUS IS CONNECTED TO EARTH ELECTRODES AT 4 PLACES WITH BOLTED JOINTS.

STANDARDISATION DEPT. TISCO			
DEPT.	ELECTRICAL		
DETAIL	TYPICAL ARRANGEMENT OF EQUIPMENT EARTHING AND NEUTRAL EARTHING FOR SUBSTATION/MOTOR HOUSE WITH TRANSFORMER CELLS		
DRN EC DATE 26/7	SCALE - NTS.	DRG. NO.	REV
CHKD DATE	FILE NO 480 TISCO STD 09032	SD-1219	

Design and Application – Earth Pit Resistance

The earth pit resistance depends upon :

- I. Resistance of the (metal) electrode,
- II. Contact resistance between the electrode and the soil.
- III. Resistance of the soil from the electrode surface, i.e. soil resistivity.

The first two factors are very small fractions of an ohm and can be neglected for all practical purposes.

The factor of soil resistivity is important in this context.

Design and Application – Soil Resistivity

Factors affecting Electrical Resistivity of the soil :

□ Nature of Soil

- Pit to be prepared with the soil, if following **soil type preference** is unavailable:
 - i) Wet marshy ground containing refuse, cinders, brine waste etc.
 - ii) Clayey soil or loam mixed with small quantities of sand.
 - iii) Clay and loam mixed with varying proportions of sand gravel stones.
 - iv) Damp and wet sand pit.
- **Dry sand, gravel, chalk, lime stone, granite, very stony ground** and locations where **virgin rock** is very **close to surface** shall be avoided.

Design and Application – Soil Resistivity

- A **site kept moist by water** flowing over it should be avoided, as the beneficial salt may be entirely removed from the soil in such situation.
- If an **imported fill exercise** (such as filling / leveling by earth/slag brought from elsewhere) has been carried out, deeper driving of the electrode may be necessary to reach layers of reasonable resistivity and to reach stable ground, such that the value of the electrode resistance remains stable if the top layers of the ground dry out.

Design and Application – Soil Resistivity

☐ Extent of Moisture:

- Below 20% the **resistivity** increases very abruptly with the decrease in **moisture content**.

(As per Fig.9 of IS:3043-1987, Reaffirmed-2001)

- The normal moisture content of soil ranges from **10%** in dry seasons to **35%** in wet seasons, and an average of **16 to 18%**.
- High moisture content in soil increases the **solubility** of existing natural elements in the soil and provides the solubility of ingredients which may be artificially introduced to improve the **soil conductivity**.

☐ Artificial (Chemical) Treatment of Soil:

- **The most commonly used substance, common salt** mixed homogeneously with fine sand in suitable proportions results in a highly conductive solution with moisture.

Design and Application – Earth Wire and Connections

- The connections should be mechanically strong.
- **For system earthing, Voltage grade** for insulated wire is selected as follows :
 - **Solid earthing** : At least 1100V grade insulated cable.
 - **Resistance earthing** : $[1/\sqrt{3} \times (\text{System Voltage})]$ grade cable up to earthing resistance and bare mild steel rod of 25 mm dia as earth lead after resistance, provided it is protected from accidental contact else insulated cable shall be used.

Design and Application – Earth Wire and Connections

- **Marking of Earthing / Protective conductor** : Bi-colour combination of **GREEN** and **YELLOW** should be such that on any 15mm length of insulated conductor, one of these colours covers between 30 - 70 % of the surface of the conductor, the other colour cover the remainder of the surface.
- **For equipment earthing,**
 - For **under ground laying**, use Galvanized Steel Flat or Mild Steel Rod painted with **GREEN** and **YELLOW** as Earth Lead.
 - For **surface laid**, use Mild Steel Flat/Rod. Flat shall be connected with bolts and welded connection shall be used for rods.



Design and Application – Earth Wire and Connections

- **For system earthing**, the earth lead (if a cable), when laid **underground** beyond the substation or the transformer cell, shall be **mechanically protected** by providing hume pipe throughout its length.
- Avoid **bends, kinks** and **coiling** of the earth lead.
- **Cross sectional area of earth wire :**
 - Cu: $\geq 2.5\text{mm}^2$ & Galvanized Steel $\geq 6\text{mm}^2$.
 - For portable equipment, current carrying conductor cross section area $< 3\text{mm}^2$. Earth wire cross-sectional area equal to current carrying conductor.

Design and Application – Earth Electrode

- An earth electrode should be of galvanized steel for pipe electrode and cast iron for plate electrode, to be able **to resist corrosion** for a long time.
- The earthing pit shall consist of pipe electrode or plate electrode with **dimensions** :
 - Plate electrode - 600 x 600 x 20mm.
 - Pipe electrode - 40mm nominal bore galvanized steel pipe,
Medium duty, conforming to IS:1 239(Part-I)-1990,
Minimum Length = 3500mm

Construction

The earthing stations shall be constructed in accordance with the drawings mentioned in following Table:

Sl. No.	Details	Drawing No.
1	Earthing Station with Pipe Electrode raised above ground level	SD-1221
2	Earthing Station with Plate Electrode raised above ground level	SD-1224
3	Deep Bore Earthing Station leveled with ground	Annexure-8
4	Earthing Station with Pipe Electrode leveled with ground (Some of the new Earthing pits constructed by Engineering)	Annexure-9



Construction

- **Distance** between any Equipment and System Earthing Electrode shall be **at least 4 meters**.
- For **outdoor sub-station of 33 kV and above, Earthing Grid/Mat** shall be provided.
- The Earthing Grid/Mat shall be located inside the fence for the sub-station. The **fence** shall be **earthed separately**.
- For **indoor sub-station of 33 kV**, if the desired value of earth resistance is not achieved, earthing grid/mat shall be provided.
- The Earthing Station Area of Drawing No. SD-1221 and SD-1224 shall be barricaded suitably by means of **wire-mesh fencing** and shall be reckoned as a part of the **protected area**.



Construction

- **Height of the wire-mesh fencing** shall be 1.2 meters and shall be earthed separately.
- In case of Drawing No. – SD-1221 and SD-1224, where barricading is not possible for extensions to existing installations, a **feeder-pillar box** of suitable size may be used to protect the earthing pit. The feeder-pillar box shall be earthed separately.
- Such **unbarricaded earthing pits** shall be at least 1.2 meters away from the roads, through fares, passage ways, etc.



Construction – Name Plate

- The name plate details of the earthing pit shall be written over the box at conspicuous location.
- To maintain records of previous testing, a **Nameplate** (SD-1225) of size 300 x 220 mm, painted with **RED** background colour for neutral earthing station and with background colour for equipment earthing station, near the earthing station shall be provided.
- Name plate shall be installed at the masonry work separately by an angle and will be raised above the level of the masonry work.



Construction – Earthing Pit Cover

- To maintain the records of previous testing, the details to be written **underside of the Earth pit cover** painted with **RED** background colour for neutral earthing station and with background colour for equipment earthing station. **No separate name plate is to be installed.**
- The Earthing Station cover shall be as per drawing no. SD-1223 for the Earthing Station drawing no. SD-1221 and SD-1224
- The Earthing Station cover shall be hinged with 180 opening for ease in inspection and maintenance work for the Earthing Station in Annexure-8 and Annexure-9.



Commissioning

- Before commissioning, the earthing pit shall be **filled-up** with a proportionate mixture of 50 kg of common salt (NaCl) in 300 kg of water and 1500 kg of soil.
- Following points shall be checked **before commissioning** :
 1. Electrode connection with the earth lead for their rigidity;
 2. Condition of earth pit and masonry work;
 3. Overall cleanliness of the area,
 4. Condition of earthing resistor and link there of.
 5. All surfaces where connections are made are free of grease, paint, dirt or any other foreign materials.

Commissioning

- **Earthing system resistance** (both individual and combined value) shall be measured with the help of "**Earth Tester**" and the combined value shall be less than 1ohm.

When grounding connections are to be made, the **first connection must be made to grounding electrode**. When disconnecting ground connections, **the connection to the grounding electrode must be last to be disconnected**.



Maximum Grounding Resistance for Overhead Shield Wire

SI No	Voltage Range	Average Span	Maximum Grounding Resistance
1	2.4 kV to 4.16kV	150ft (45.7 Mtr)	5 ohm
2	6.9 kV to 13.8 kV	200ft (60.9 Mtr)	10 ohm
3	23 kV and 34.5kV	300ft (91.4 Mtr)	15 ohm
4	69kV	400ft (121.9 Mtr)	20 ohm
5	115kV and 132kV	600ft (182.9 Mtr)	30 ohm
6	230kV	800ft (243.9 Mtr)	40 ohm

Note:

- The max. resistance is suitable for lightening stroke of 50kA with not more than 50% of stroke current going to ground over one down conductor.
- If spans are one-half the average lengths given, the max. resistance may be doubled; likewise, if the spans are double the average length given or the overhead ground wire is grounded at every second pole, the maximum resistance should be halved.

Earthing in Potentially Hazardous Area

- The **connection** between metal part to be grounded and the grounding conductor shall be made **mechanically and electrically secure** by using adequate metallic fitting.
- The **grounding conductors** shall be sufficiently **strong and thick**, and the portions of conductor which are likely to be corroded or damaged shall be **well protected**.

Earthing in Potentially Hazardous Area

- For grounding conductors which shall not reach hazardous high temperature due to anticipated maximum fault current, following shall be used.
 - **Protection against lightning** shall be provided in accordance with specific guidelines for installation in the hazardous locations given in IS:2309 (Code of practice for the protection buildings and allied structure against Lightning).
 - **Interconnection system** with other buried metal services and/or earth terminations for equipment grounding for equalizing the potential distribution in the ground should preferably be made below ground.
 - **Portable/Transportable apparatus** shall be grounded with one of the cores of the flexible cable for power supply.
 - **The earth continuity conductor and the metallic screen**, wherever provided for the flexible cable, should be bonded to the appropriate metal work of the apparatus and to the earthing pin of the plug.
 - **Efficient bonding** should be installed where protection against stray currents or electrostatic charges is necessary.

Earthing in Potentially Hazardous Area

Earthing and Bonding of Pipelines and Pipe Racks:

Unless adequately connected to earth elsewhere, **all utilities and process pipelines** should be **bonded to a common conductor** by means of earth bar or pipe clamps and **connected to the earthing system** at point where pipelines enter or leave the hazardous area.

- **Neutral and protective conductor** shall not be connected together or combined in a single conductor in a hazardous area.
- For power systems at all voltage levels installed in **zone-0**, due attention should be paid to the limitation of earth fault currents (magnitude and duration). Inst. earth fault protection shall be installed.
- To avoid **dangerous sparking** between metallic parts of the structure, potential equalization is always required for installations in Zone-0, and zone-1 areas and may be necessary for installation in zone-2 areas.
- The **bonding system** may **include** normal protective conductors, conduits, metal cable sheaths, steel wire armoring, and metallic part of the structure, but shall not include neutral conductors.



BARRICADED EARTH PIT ABOVE GROUND LEVEL

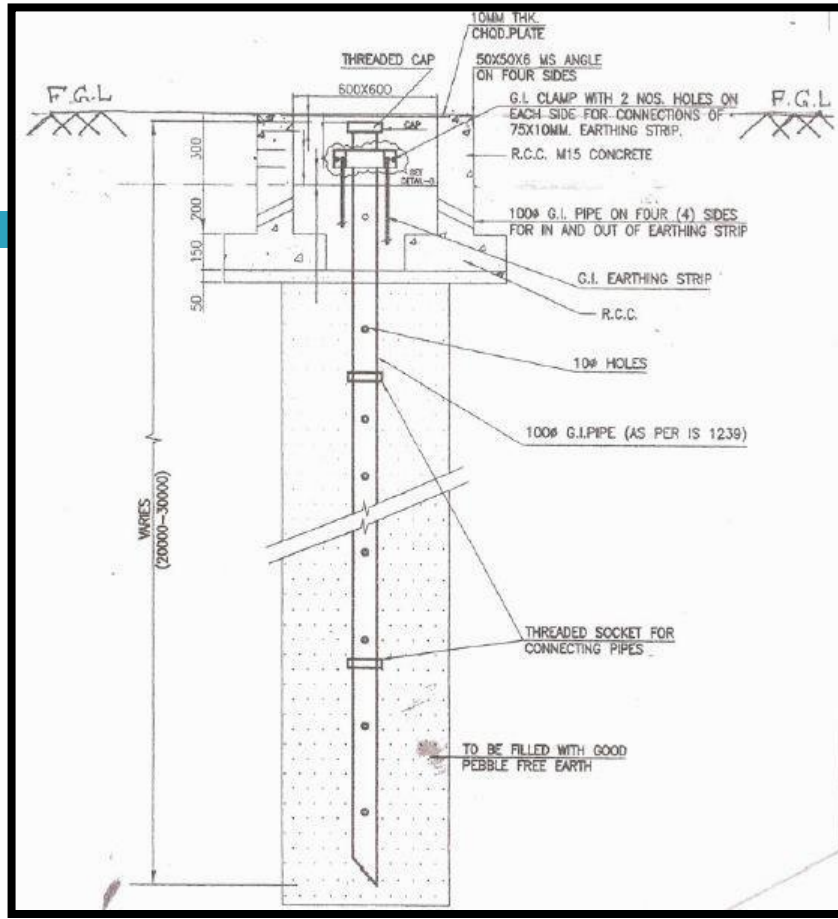

1. The Earthing Station cover/CHQD plate shall be hinged with 180 degree opening for ease in inspection or maintenance work.
2. To maintain the record of previous testing, the details to be written under side of the cover.



TYPICAL ARRANGEMENT OF DEEP BORE EARTHING STATION

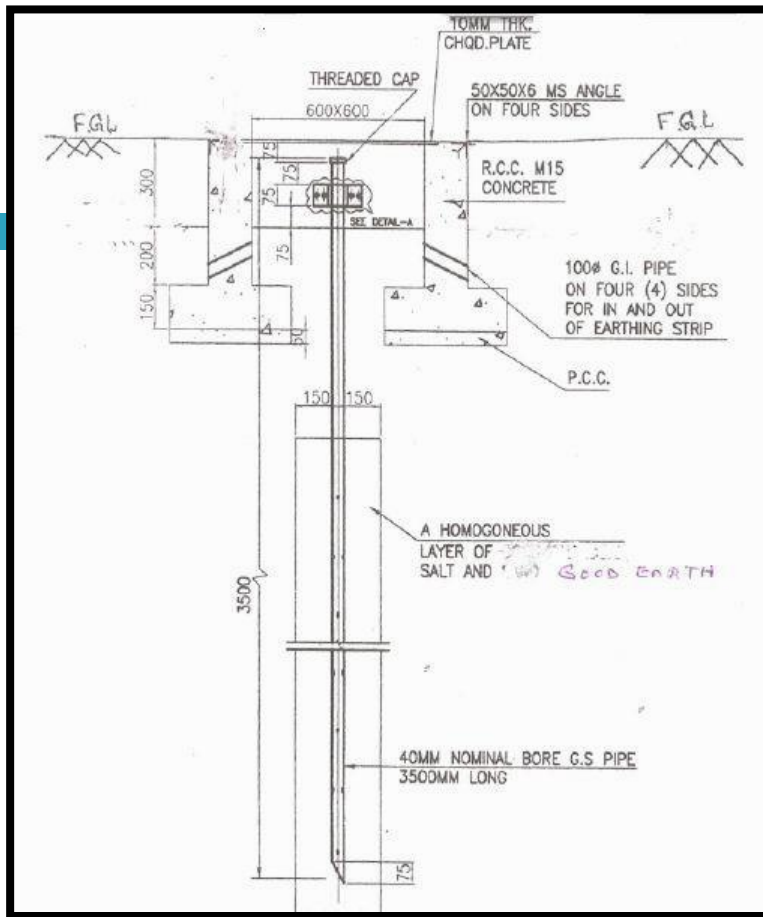

TYPICAL ARRANGEMENT OF GENERAL EARTHING PIT WITH PIPE ELECTRODE

1. The Earthing Station cover/CHQD plate shall be hinged with 180 degree opening for ease in inspection or maintenance work.
2. To maintain the record of previous testing, the details to be written under side of the cover.





DETAILS WRITTEN UNDER EARTH PIT COVER WITH GROUND LEVEL

ELECTRICAL AREA CLASSIFICATION FOR FLAMMABLE GASES AND VAPOUR



Purpose



- The objective is notional classification **into zones** (I/II and III) based on the likelihood of existence of explosive/gas mixtures for the selection of electrical apparatus that is protected to a degree appropriate to the risk involved.

Scope



- This standard is applicable for electrical equipment only and gaseous like Nitrogen, Oxygen, Argon etc are out of scope. This is also not applicable to mining applications, dust laden atmosphere, catastrophic failure, Ignition due to static electricity, lightening strikes, open flames, welding, mechanical sparks or hot surfaces of process equipment and heaters.

Classification of Hazard area

- **Zone 0 :**
 - Gas or vapour present all the time
 - Usually vapour space above liquid at top of the tank
 - Over 1000 hrs/Year or >10% of the time
- **Zone 1 :**
 - Areas where specific equipment should be used
 - Gas and vapour will be present for longer periods of time
 - 10-1000 hours/year or 0.1-10% of the time
 - Explosion safety equipment that has higher safety than zone 2 equipment
- **Zone 2 :**
 - Gas mist or vapour would be present only in abnormal condition
 - Explosion safety compliant equipment should be used
 - Under 10hrs/year or 0-0.1% of the time

Extent of Hazardous area

- Based on the following condition we classify hazardous area
 1. Properties of Gases
 2. Surrounding and Environment- Open air or enclosed etc.
 3. Location of source- Ground or elevated
 4. Other disturbing forces- wind direction etc

Group classification

- Hazard area equipment is classified on the types of gases present:
 - **Group I** : For mining application
 - **Group II** : For general industry
- Group II equipments can be further classified on the basis of gases present in industry
 - **Group IIA**: Industrial methane, propane and petrol
 - **Group IIB**: Ethylene, Coke oven gas and other industrial gases
 - **Group IIC**: Hydrogen, acetylene, carbon disulphide

Temperature classification

- Ignition temperature is the temperature of the heated surface at which gas/vapour ignites
- Ascertained using precisely defined test equipment (IEC60079-4)
- Flammable gases are classified into temperature classes using ignition temperature
 - Refer Standard SS/Elec-07 for data

Type of Protection

- Electrical equipment should be designed such that they do not provide source of ignition
- Type of protection should be suitable for the zone in which it is to be installed

Electrical Area Classification

- Classification into zones based on gaseous hazard and extent of hazard
- Classification of gases into group and temperature class
- Selection of equipment based on type of protection

Working in Electrical Rooms



Objective

The purpose of this safety standard is to achieve adequate safety of personnel working in Electrical Room. This outlines the safety requirements for the personnel's working in Electrical rooms.

Safety Guidelines

- The electrical installations for medium, high and extra high voltage should have a danger notice



- **Following tools and devices shall be made available in Electrical rooms**



Kool Koat



Safety Belt



Safety gloves



Electrical overshoes



Earthing device



Power tester

- **Do not** wear loose clothing, metal watch straps, bangles or finger rings while working on electrical appliances



finger rings



bangles



metal watch straps



- **The Electrical installations for high and extra high voltage shall have a running tap water and in case of electric burns , the burnt portion should be cooled down using water.**

✓ **Service water should not be used, only drinking water to be used**

- **No high and extra high voltage system/switchgear which has been disconnected , for 6 months of more for any maintenance job should be energized without testing and written clearance by testing department**

- **Records of all tests, repairs, maintenance work of all electrical equipments should be kept in registers.**



- **Precautions against auxiliaries circuits :**
Precautions to be taken to ensure that control circuits to equipment are disconnected from the supply before work

- **Detachable type Screw driver should not be used as it may fall and cause flashover**
- **Bus charging of the 3 kv and above to be avoided in evening hours and 1 hr before shift change.**



- **The digital multi meter (DMM) shall comply the safety requirement**

✓ Safety Class – **Cat III** for voltage range of DMM up to 1000 V

✓ Safety Class – **Cat IV** for voltage range of DMM to 650 V

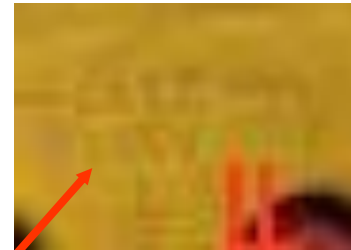

- **Hand lamps and torches should be insulated type, not metallic**



- **Always use portable hand lamps of insulated safety type and provided with insulated handle and insulated wire guard**

- ❑ **Don't attempt to disengage a person in contact with live apparatus without standing on rubber mat or dry board.**
- ❑ **Don't touch his body, use dry wood/ insulated rod**

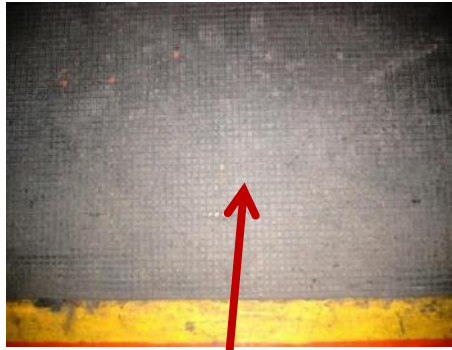

**rubber mat
/ dry board**



**Wood/
insulated rod**

- **Make sure that voltage transformer is dead and isolated before it is examined. Care to be taken to ensure that transformer is not liable to be live due to feed back via the secondary side**
- **Earthing of equipment to be done as per standard eg;**

Every earthing system shall be tested for its resistance to earth on a dry day not less than once a year

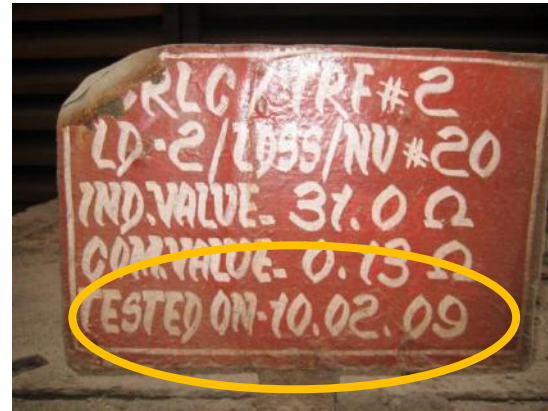

- **Lead Acid Battery Rooms**



- ✓ **The battery rooms should have the explosion proof lighting, exhaust fan and acid resistant floors**
- ✓ **Lead acid battery rooms should have **one packet of lime (1/5 kg)** permanently to neutralize leaked acid**

• **Artificial Respiration**

- ✓ **In every high and extra high voltage sub section, an artificial respirator to be provided**
- ✓ **Do not discontinue artificial respiration until recovery or death declared by doctor. It may take even more than 2-3 hours for recovery**



- **Fuse**

- ✓ **When removing the fuse, pull out the supply end first and during replacing , the supply end should be put last**
- ✓ **No attempts to be made to rewire a non-wire able fuse**
- ✓ **Switch Fuse Unit (SFU) to be discarded if phase barrier are found damaged**

- ✓ Fuse should be replaced with original make and should not be interchanged

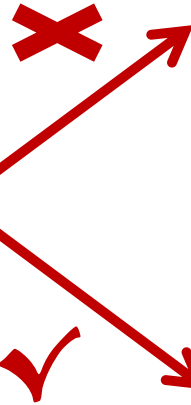

- 
- **MCCB used in Motor feeder shall have auxiliary contact for tripping of contractor in case of MCCB tripping**
 - **After switching off the isolator no live parts shall be exposed in the MCC module . If it is so it shall be replaced.**
 - **Under trickle charging conditions stratification of the electrolyte can occur and it is recommended that at intervals of approximately 2 years the batteries should be charge and discharge cycle, alternatively a boost charge to ensure its reliable operation**

• Electrolytic Capacitors

- ✓ Electrolytic capacitors deteriorate when out of use or in store
- ✓ Spare capacitors should be kept permanently charged at their rated voltage and should therefore be stored in charging rack with suitable interlock to prevent shock when handling
- ✓ Spare capacitors having paper dielectric need not be kept charged but should be kept dry



- **Circuit Breaker**

- ✓ **Racking - in and Racking – out of breakers having isolating contacts in vertical plane are very risky and these breakers shall be racked – in or out under protection plasma shield & Kool coat or through Tele – breaker racking device**



- 
- ✓ **HV Breaker trolley shall always be pushed and not pulled to avoid toppling and fall on the person**
 - ✓ **Isolation of the withdraw able metal clad circuit breaker should be delayed for not less than 10 minutes after operation on fault to allow for the dispersal of any ignitable gases in the live spouts**

- **Power testing not to be carried out on moving equipments such as EOT cranes, oven machines in coke oven, loco etc as there are chances of flash over due to sudden jerk in the testing leads. Proper clearance to be taken to ensure that equipments stand still while working**
- **No work to be carried out in panel exposed to 415 volt supply**

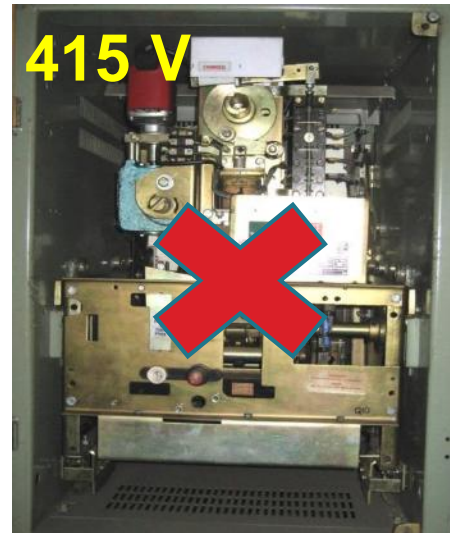

HANDLING OF ELECTRICAL PANELS



HANDLING OF ELECTRICAL PANELS

To Define Safety Precautions for

- Lifting of Electrical Panels
- Shifting of Electrical Panels

HANDLING OF ELECTRICAL PANELS

Associated Hazards

- **Injury** to operators
- **Injury** to other personnel
- **Damage** to Capital Equipment

HANDLING OF ELECTRICAL PANELS

Applicability

All Departments

All **Contractors** and their employees

HANDLING OF ELECTRICAL PANELS

Background

After unloading of Electrical Panels at the entry point of the building at ground level, the panels are either,

- **shifted** to their installation positions **at ground level**

OR

- **lifted to upper floors** before shifting to installation positions.

HANDLING OF ELECTRICAL PANELS

Before Moving Electrical Panels

- Provide **slings/chains from** the top anchoring points of the **panel**.
- Fix the **slings with** an overhead strong anchorage point of the **building**.
- Take **minimum 4** nos. of same diameter **pipes** in good condition having length greater than the width of the panel.
- Keep the **pipes below** the **panel**.
- **No man** should be standing **behind the panel** when keeping the pipes.
- **Stop** the panel from **sliding**.
- Secure the **pipe with wedge** temporarily during this operation .

HANDLING OF ELECTRICAL PANELS

Moving Electrical Panels – using Monorail

- Move the panel by **rolling over the pipes** keeping its **top anchored** with the monorail through a clamp or a chain pulley block.
- Push the panel slowly so that the **pipes that roll** out below the panel **from its rear** side are **placed** again below the panel **from its front** side .
- Ensure that **minimum 3 pipes** always **support** **the centre of gravity** of the panel adequately.
- **Select** the type and size of pipes based on size and weight of the panel.

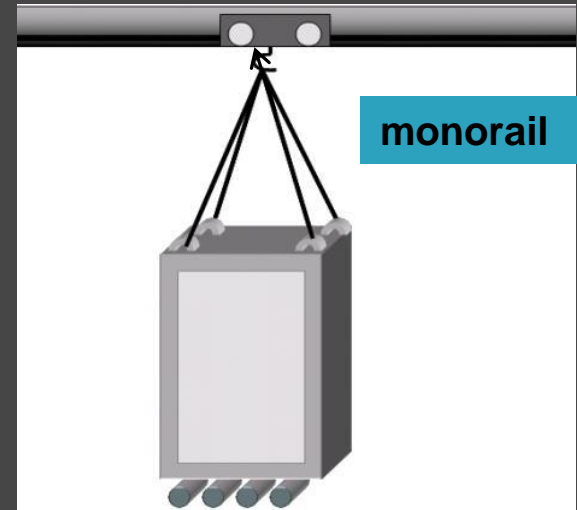

HANDLING OF ELECTRICAL PANELS

Moving Electrical Panels – using Chain Pulley Block

- lift panel slightly over the floor and move



HANDLING OF ELECTRICAL PANELS

Moving Electrical Panels – using Standard Panel Lifting Trolley

- Move the panel handling trolley towards the panel kept on ground so that the **top frame of the trolley** comes **over the panel**.
- Attach the end of the rope of the hydraulically operated rope pulley arrangement to the **top anchor points** of the panel.
- **Lift** the panel attached to the rope with the manual actuation of a hydraulic Cylinder operated **through a trolley mounted power pack**.
- The **whole trolley** with the lifted panel is then **moved** to its installation position.

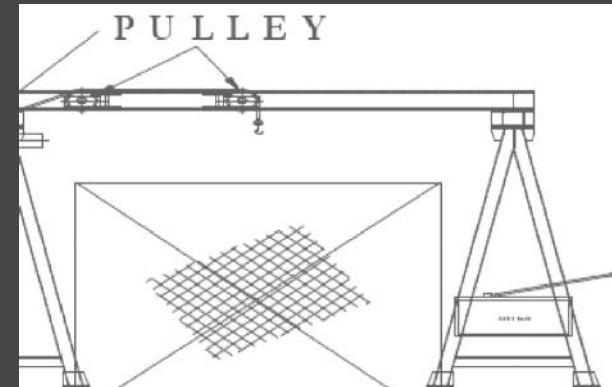

HANDLING OF ELECTRICAL PANELS

Moving Electrical Panels

- **Pipes** should be **kept below the panel** and the **panel top** should be kept **anchored** with the monorail when the panels are moved to the designated place over a cutout/opening on the floor for the final installation.
- If monorails **does not exists**, provide suitable **anchorage points** of adequate strength **from the roof top or on the side walls** for holding the top points of the panels with slings.

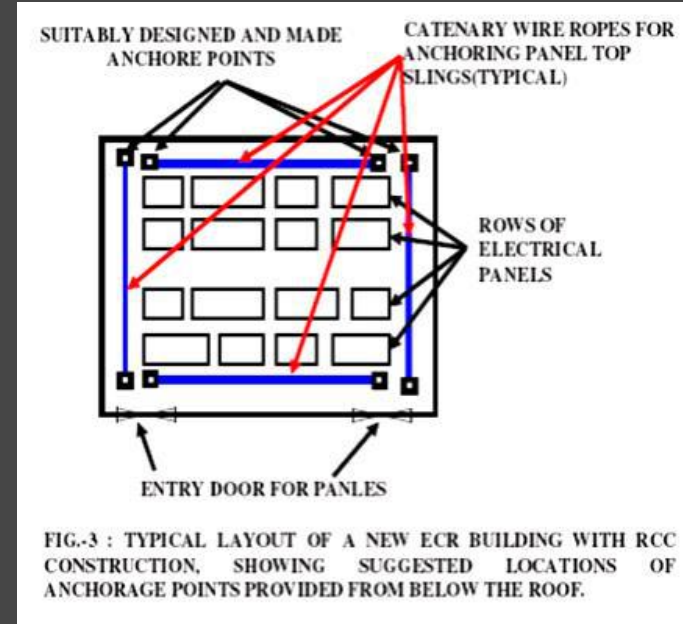

HANDLING OF ELECTRICAL PANELS

Moving Electrical Panels – in Multistoried ECR Building

- Provide one projected monorail of adequate capacity from the roof level of the top most panel floor, clearing the panel landing platforms at each floor.
- The platforms should include the **maximum panel width** at each floor of the ECR building.
- At each landing platform, provide **open slot and detachable hand railing** below the centre line of the monorail.

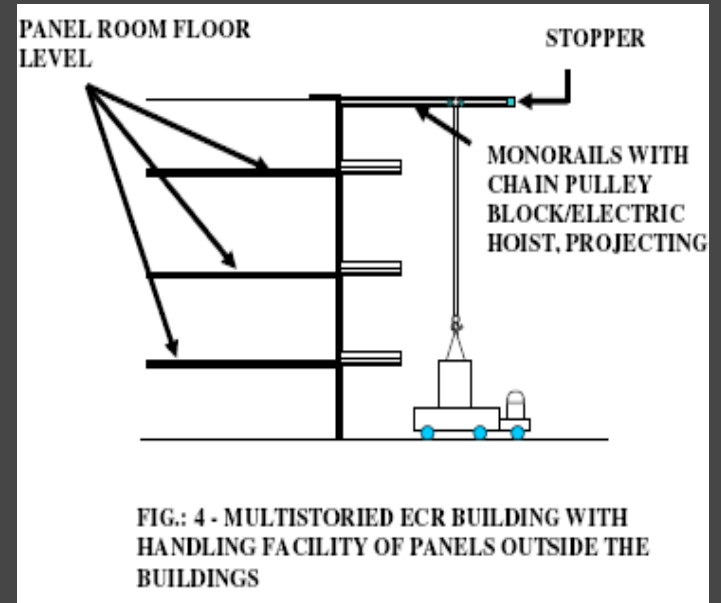

HANDLING OF ELECTRICAL PANELS

Moving Electrical Panels – in Multistoried ECR Building

- For **lower level handling**, **panel landing openings** at higher floors should be created.
- To create such openings, provide **hinged/sliding chequered plates/coverings** over landing openings which should be moved to facilitate the proper placement of panel.
- The **monorails at the roof** level at each floor need to be kept **close to the panel landing platform**, for subsequent panel movement inside the floor.

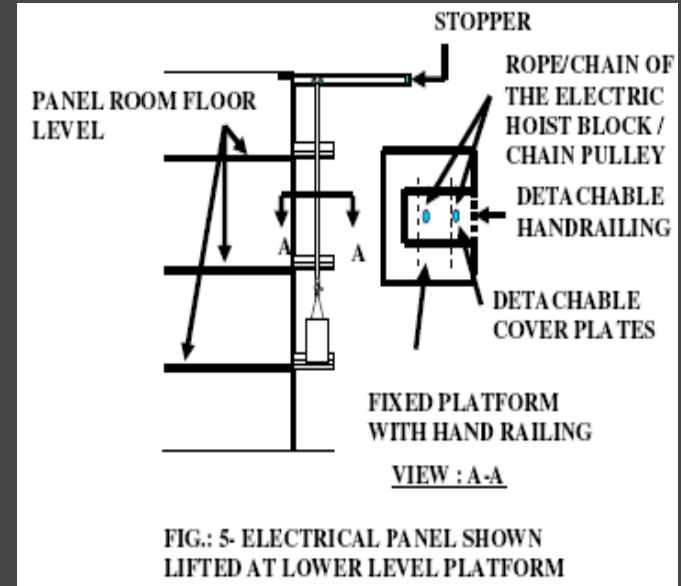

HANDLING OF ELECTRICAL PANELS

Monitoring & Reviewing

Frequency	Mechanism	Record	Responsibility
Before and during panel lifting	Inspection	Inspection Record	Line Engineer /Consultants /Contractor

Checklist		YES	NO	NA
SL. No.				
1	Top anchoring point of panel is provided			
2	Panel is secured firmly with the top anchoring point			
3	Minimum 4 nos. of pipes of suitable diameter and strength are selected			
4	If using a chain pulley block then select it according to the weight of the panel			
5	If using a wire rope for anchoring the panel then select it according to the weight of the panel			
6	Steel brackets are properly welded to the main beam of the building			
7	If using a panel lifting trolley then the panel is properly anchored to the rope pulley arrangement			
8	Pipes are kept below the panel when the panels are moved to the designated place over a cutout/opening on the floor for the final installation			
9	Panel top is kept anchored when the panels are moved to the designated place over a cutout/opening on the floor for the final installation			
10	When large nos. of panels are required to be moved, catenary steel wires of required strength are provided all along the room from side wall to side wall for anchoring the top panel slings during movement of the panel			
11	In a multistoried ECR building, one projected monorail of adequate capacity from the roof level to the top panel floor is provided			
12	Panel landing platform includes the maximum panel width at each floor			
13	At each landing platform, open slot and detachable hand railing below the centre line of the monorail is provided			
14	Hinged/sliding chequered plates/coverings over landing openings is provided clearing the chain pulley lifting block or the lifting slings/tracks holding the panel top.			
15	The monorails at the roof level at each floor is kept close to the panel landing platform			



THANK YOU

THANK YOU